



Operating Instructions  
Component of refrigerant compressors  
(EN 12693)

Electronic Oil Level Controller OLC



Please read these operating instructions carefully to ensure a safe operation and keep the same for further use.

© 2024 Armaturenwerk Altenburg GmbH | Am Weißen Berg 30 | 04600 Altenburg, Germany





## Contents

Safety.....	4
Authorized personnel.....	4
Residual hazards.....	4
Symbols used for safety information.....	4
General safety information.....	5
Other information.....	5
Description of Oil Level Controller.....	6
Operating principle.....	6
Product description.....	7
Marking.....	8
Technical parameters.....	8
Approvals and guidelines.....	9
Design features.....	10
Transport and storage.....	10
Installation.....	10
Principles.....	10
Preparing the installation.....	11
Installation.....	11
Electrical connection.....	12
Commissioning.....	13
Principles.....	13
Steps of commissioning.....	14
Operation, Maintenance and Repair.....	15
Principles.....	15
Repair.....	15
Dismantling and Disposal.....	16
Principles.....	16

## **Safety**

The electronic Oil Level Controller, OLC, hereinafter referred to as Oil Level Controller, has been designed for installation to refrigerant compressors into refrigeration systems according to EN 378, hereinafter referred to as Systems. It may only be put into service if installed into the System unchanged in accordance with these instructions and as whole in compliance with the statutory provisions. The Oil Level Controller incorporates state-of-the-art technology and has been built according to the applicable regulations. Great value has been set upon the user's safety. The operation manual is integral part of the contract and shall be kept throughout the entire life of the Oil Level Controller.

### **Authorized personnel**

Only trained and instructed personnel shall be allowed to work on the Oil Level Controller and the System. As regards the qualification and expertise of the personnel the applicable rules and guidelines shall apply.





### **Residual hazards**

Unavoidable residual hazards may emanate from the Oil Level Controller. Every person working on this device shall therefore carefully read these instructions.

To be observed for example:

- the generally accepted safety regulations
- the EC directives,
- norms (e.g. EN 12693) and national provisions.









### **Symbols used for safety information**

	<p><b>DANGER!</b> Instructions on how to prevent imminent serious hazards to persons. Imminent most serious injuries or death as a possible consequence. Any non-observance may result in an immediate failure of the Oil Level Controller.</p>
	<p><b>DANGER!</b> Instructions on how to prevent imminent serious hazards to persons. Imminent most serious injuries or death as a consequence of electric shock possible. Any non-observance may result in an immediate failure of the Oil Level Controller.</p>
	<p><b>WARNING!</b> Instructions on how to prevent potential serious hazards to persons. Avoidable serious to very serious injuries or death as a possible consequence. Any non-observance can cause the Oil Level Controller to fail.</p>
	<p><b>CAUTION!</b> Instructions on how to prevent a minor hazard to persons. Minor, reversible injuries cannot be excluded. Any non-observance may result in a medium-term failure of the Oil Level Controller.</p>
	<p><b>ATTENTION!</b> Instructions on how to prevent possible damage to equipment. Minor, reversible injuries cannot be excluded. Any non-observance may result in a medium-term failure of the Oil Level Controller.</p>

## General safety information

These operating instructions are based on the safety requirements of EN 378-2, EN 12693, EN 61000-6-3:2007 + A1:2011, EN 61000-6-2:2005, EN 61326-2-3 as well as of EN 61010-1:2010.

Instructions on how to prevent hazards in all cycles of service life:

	<p><b>DANGER!</b> Risk of bursting if operated beyond the technical parameters. Most serious injuries and immediate system failure possible. Observe the technical parameters.</p>
	<p><b>DANGER!</b> Risk of bursting during operation / standstill OLC2 outside the technical parameters. Most serious injuries and immediate system failure possible. Limit compressor suction pressure / standstill pressure to max. 100 bar.</p>
	<p><b>DANGER</b> Fire hazard when operating with A2L/A3 refrigerants. Take appropriate measures to prevent flammable atmospheres, e.g. due to leaking or accumulating refrigerant. The OLC must be located outside of potentially flammable zones.</p>
	<p><b>DANGER!</b> Most serious injuries and even death possible due to electric shock. Before working on the electrical system de-energize the lines and check for zero-voltage condition. Observe the technical parameters.</p>
	<p><b>WARNING!</b> Damage due to improper handling. Serious injuries and system failure possible. Never use the Oil Level Controller as transport, lifting or lashing points.</p>
	<p><b>WARNING!</b> Any non-observance of the instructions may cause the Oil Level Controller to fail. Avoidable serious to very serious injuries or even death possible. Installation, operation and maintenance by authorized personnel only.</p>
	<p><b>WARNING!</b> Risk of service fluid being released. Depending on the kind of service fluid serious to very serious injuries or death may be possible. Wear personal protection equipment (e.g. respirator, gloves).</p>
	<p><b>CAUTION!</b> Very cold or very hot surface temperatures possible. Frostbites/ burns possible. Wear personal protection equipment (e.g. gloves, protective clothing).</p>

## Other information

The information contained herein represents to the best of our belief our knowledge at the time when these instructions had been prepared. It shall serve as code of practice to ensure a safe handling of the Oil Level Controller when it comes to transport, storage, installation, commissioning, maintenance and dismantling/disposal. A final decision as to whether the Oil Level Controller suits the purpose is to be taken by the user, however. This information shall not be deemed a warranty of quality or any other guarantee.

Any modification of the Oil Level Controller and operation under other than the prescribed parameters shall not be permitted and will make the conformity declaration null and void and all liability claims will get lost.

## Description of Oil Level Controller

A Hall sensor and a magnetic system installed in the float measure the oil level in the compressor. Depending on the oil level and the magnetic field strength changed by it a variable induced voltage is produced. The latter is evaluated by the electronic system and the LEDs and the solenoid valve actuated accordingly. As soon as the oil level reaches the alarm threshold (see operation), the Oil Level Controller switches the changeover contact to alarm condition with a delay of 90 seconds. This signal can be used for compressor disconnection or data processing. As long as the alarm condition is on, the compressor is permanently supplied with oil to get the oil level back to normal. If successful, the alarm will be reset after the oil level has risen again to a defined value.

To recognize immediately a compressor "without oil filling", a "Power on Logic" has been integrated in the software. The delay times of "Filling" and "Alarm" are disabled. It is thus guaranteed that a compressor without oil filling does not run for 90 seconds before the alarm is triggered, but can be stopped immediately.

### Operating principle

The oil level indicator is split into segments:

1. Normal filling between 40 % and 60 % of liquid level indicator
2. Critical filling between 25 % and 40 % of liquid level indicator, and
3. Alarm threshold at < 25 % of liquid level indicator.

When the green LED lights up, the Oil Level Controller is ready for operation and the oil level is at normal. If the oil level is below normal for more than about 10 seconds, the solenoid valve is switched on so that oil is filled into the crankcase up to 60 % sight glass height (max. filling level). Now, the valve closes again. The delay of 10 seconds may be useful for certain compressor types and applications because the oil level fluctuates upon compressor start and without the time delay the oil filling would commence although there is a sufficient amount of oil. Thus, the compressor shall be prevented from overfilling.

If the oil level drops in a low-pressure system despite active oil filling to a "critical area", it may be caused by too low differential pressure (oil pressure minus suction pressure). In such case the differential pressure has to be increased so that a sufficient amount of oil can flow in. This can be achieved by suitable differential pressure valves.

To avoid a shortage of oil, AWA recommends leaving the Oil Level Controller on even if the compressor is on hold.

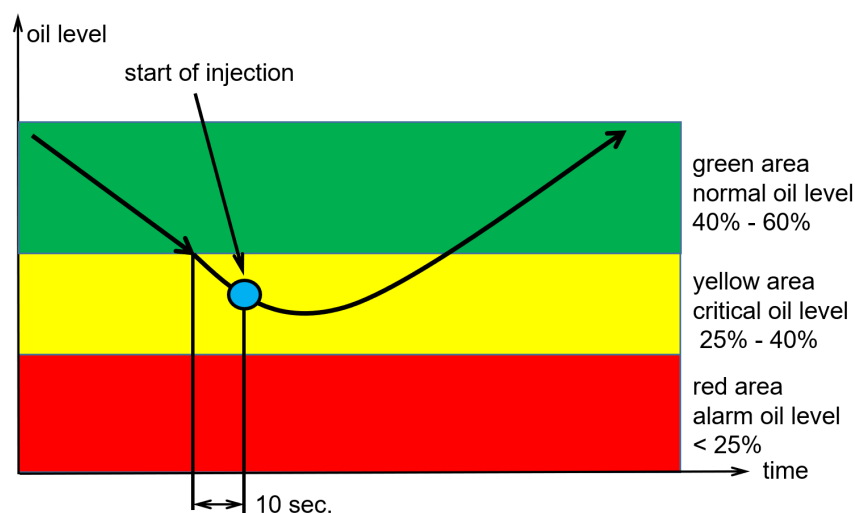

figure 1: Logic of filling – critical area

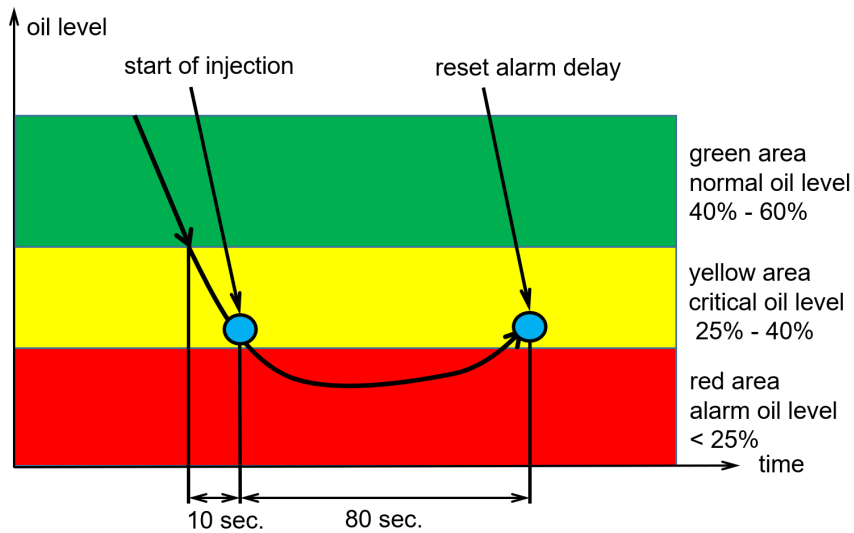

figure 2: Logic of filling – Delay time for alarm output

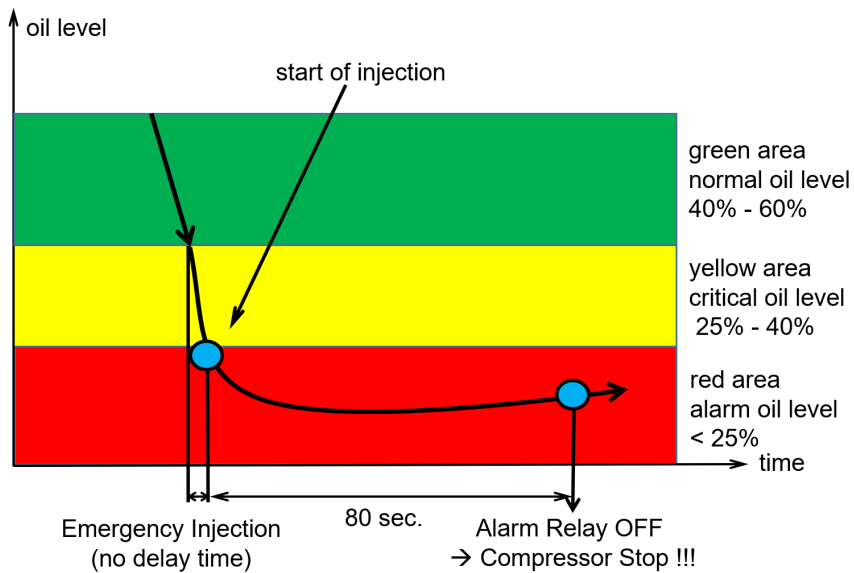

figure 3: Logic of filling – Emergency injection

## Product description

The Oil Level Controller is suitable for mounting on refrigerant compressors according to EN 12639 in refrigeration systems and heat pumps according to EN 378 in order to monitor and control their oil level.

Observe the direction of flow.

## Marking

The Oil Level Controller oil regulation system is marked in accordance with EN 12693.

The CE marking is carried out in accordance with Low Voltage Directive 2014/35/EU and EMC Directive 2014/30/EU, the UKCA marking is carried out in accordance with Electrical Equipment (Safety) Regulations SI 2016/1101 and Electromagnetic Compatibility Regulations SI 2016/1091.

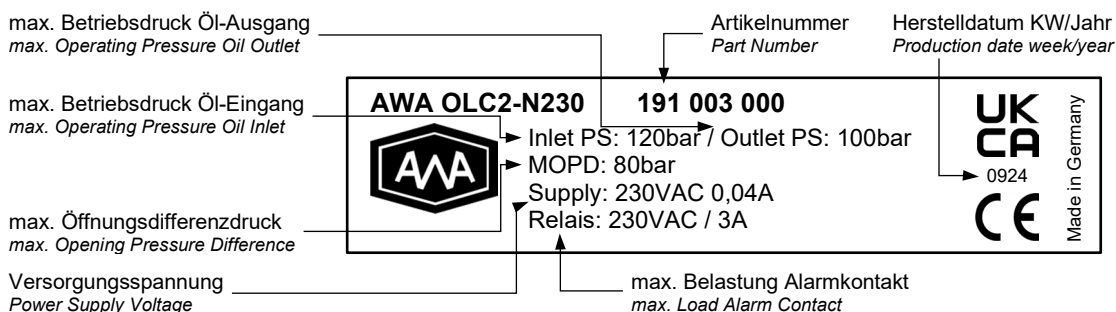

## Technical parameters

### Leak test:

acc. to DIN 8964-3 (<4.1 g/a R-134a at 10 bar)

### Strength test:

acc. to EN 12693 at 1.1-fold PS of the respective room

### Classification:

Component of refrigerant compressors acc. to EN 12693

<b>Electrical characteristics:</b>	OLC1-N24	OLC1-N230	OLC2-N24	OLC2-N230
Supply voltage	24 V <sub>AC</sub> (+10/-15 %)	230 V <sub>AC</sub> (+10/-15 %)	24 V <sub>AC</sub> (+/-10 %)	230 V <sub>AC</sub> (+/-10 %)
Current consumption	0,4 A	0,04 A	0,4 A	0,04 A
Frequency	50...60 Hz			
Alarm contact	max. 3 A, 230 VAC, floating			
Time delay	Alarm: 90 s; Filling: 10 s			
Vibration resistance	max. 4 g, 10 ... 250 Hz (EN 60068-2-6)			

<b>Pressure characteristics:</b>	OLC1	OLC2	
max. operating pressure PS:			Remark: Chamber 1: Oil inlet up to solenoid valve Chamber 2: Oil outlet and measuring chamber  see also <i>figure 4</i>
Chamber 1	60 bar	120 bar	
Chamber 2	60 bar	100 bar	
Test pressure PT:			
Chamber 1	66 bar	132 bar	
Chamber 2	66 bar	110 bar	
MOPD	40 bar	80 bar	

<b>Operating conditions:</b>	
Media compatibility	mineral oils, synthetic and ester oils, HFKW, CO <sub>2</sub> , HC, other refrigerants on request
Media/ Storage temperature	-40...+80 °C
Ambient temperature	-40...+50 °C (static)
Degree of protection	IP 65 (EN 60529) (when fitted with original AWA cable)
Humidity	0 – 80 % RH (non-condensing)



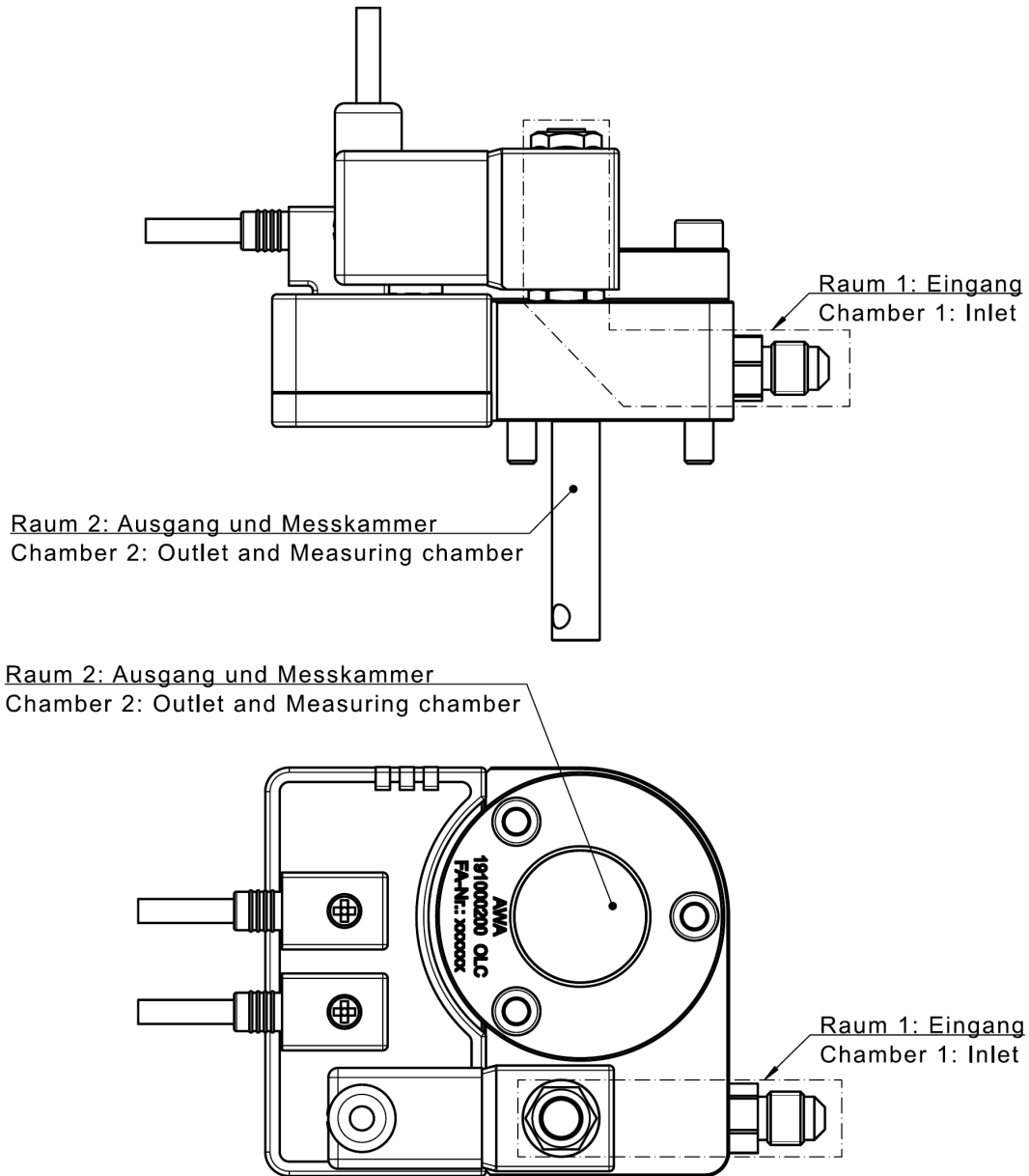

figure 4: Illustration of chambers for pressure characteristics

## Approvals and guidelines

### CE conformity

Low-Voltage Directive	2014/35/EU
RoHS Directive	2011/65/EU
EMC Directive	2014/30/EU
Reach Regulation	Regulation (EC) No. 1907/2006

### UKCA conformity

Electrical Equipment (Safety) Regulations	SI 2016/1101
Electromagnetic Compatibility Regulations	SI 2016/1091
Restriction of the Use of Certain Hazardous Substances in EEE	SI 2012/3032

### Norms applied:

EN 378-2;	EN 61326-2-3	EN 61010-1:2010
EN 12693	EN 61000-6-2:2005	
	EN 61000-6-3:2007 + A1:2011	

## Design features

- The material of the Oil Level Controller components has been selected in conformity with EN 12693 thus guaranteeing the reliability for the operating range indicated.

## Transport and storage

See technical parameters.

## Installation

### Principles

- The Oil Level Controller shall be arranged in the System so that it can be properly operated and maintained.



#### **DANGER!!**

Damage of Oil Level Controller possible.  
Serious injuries and system failure possible during operation.  
Oil Level Controller to be installed without additional loads (forces, vibrations etc.).

- In particular it is necessary to provide for sufficient space so that the Oil Level Controller can be properly mounted by means of a tool at the required torque.
- Cables must be routed without tension and fastened with suitable means to relieve connectors from mechanical stress.
- Only authorized personnel shall be allowed to do the installation.



#### **DANGER!**

Any non-observance of these instructions may cause the Oil Level Controller to fail.  
Most serious injuries and death possible.  
Installation and operation by personnel being familiar with refrigeration systems only.



#### **DANGER!**

Any non-observance of these instructions may cause the Oil Level Controller to fail.  
Most serious injuries and death possible.  
Only qualified electricians shall work on electrical systems.

- No modifications of the Oil Level Controller permitted. If modifications become necessary, they have to be agreed in writing beforehand with the manufacturer.



#### **WARNING!**

Product features may change.  
Avoidable serious to very serious injuries or even death may be a consequence.  
Any modification of the Oil Level Controller needs to be agreed with the manufacturer beforehand.

- The Oil Level Controller must be mounted in such a way that it is protected from direct exposure to sunlight.
- High-frequency current peaks of the supply, e.g. by use of frequency converters, shall be suppressed by suitable measures, e.g. by means of a line reactor.
- Magnetic fields in the direct surroundings are to be avoided by suitable means, e.g. by means of shielding.

## Preparing the installation

- The Oil Level Controller can be provided with additional transport protection means. To avoid contaminations such means of protection should be removed just shortly before installation.
- Check parts for completeness.
- Check all sealing surfaces for cleanness.
- Align the Oil Level Controller horizontally (tolerance  $\pm 1^\circ$ , see ILL. D).

	<p><b>ATTENTION!</b>          Possible damage of interior component parts.          Malfunction due to oxidation/contamination of interior component parts.          Transport protection to be removed just shortly before installation.</p>
---	---

## Installation

1. Do not dismount the Oil Level Controllers with Rotalock connection or pre-finished adapters prior to installation. Grease the O-rings prior to installation.
2. Oil Level Controller with Rotalock adapter: Place PTFE seal ring in compressor (ILL. A).
3. Oil Level Controller with hole-flange adapter: Place O-ring in adapter (ILL. B). Use original screws of the compressor. Observe the torques specified by the compressor manufacturer.
4. Oil Level Controller with screw adapters (not ready for installation) as shown in ILL. C to be installed in the following order:
  - a. Screw the adapter incl. flange ring and O-ring into the compressor.
  - b. Fasten Oil Level Controller by adapter flange, screws and O-rings as shown.
  - c. Align the oil regulating system horizontally (ILL. D)
  - d. Initially hand-tighten the Oil Level Controller with the adapter. Make sure the components parts are in unstrained position, avoid damage.
  - e. Tighten the Oil Level Controller in a clockwise sequence in minimum 2 steps using a positive tool until the specified torque has been reached.
5. Take the removal space for the coil into account (ILL. E).
6. Note: Coil may become hot during operation (ILL. F).
7. For recommended torques see ILL. G.
8. Ensure strain and pressure relieved cable routing.
9. Use of solvents, cleaning agents, coating and preservative agents as well as insulation materials only upon written approval by Armaturenwerk Altenburg GmbH.

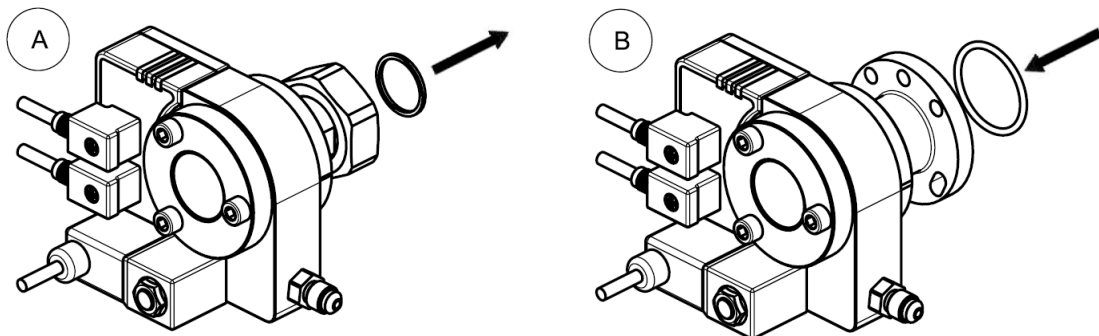

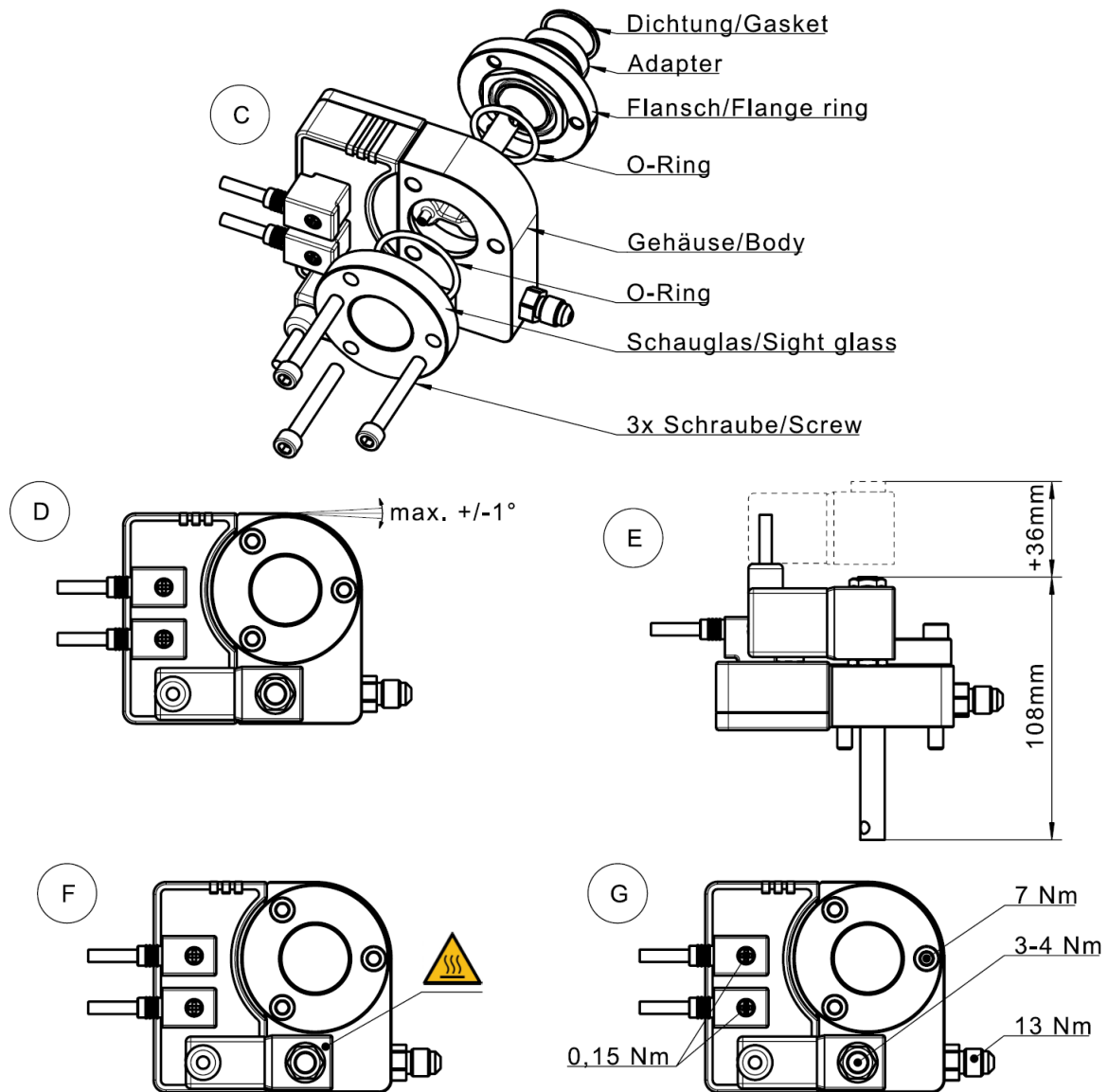

figure 5: Installation



**WARNING!**

Excessive torques or non-observance of the installation sequence may cause failures. Serious injuries and system failures possible during operation. Observe the torques.

**Electrical connection**

1. Disconnect the line prior to installation and check for zero voltage condition.
2. The supply voltage must comply with the permissible voltage and frequency of the Oil Level Controller.
3. Check the cable and plug for insulation faults.
4. Connect the plug as shown in Fig. 8.
5. Press the connector firmly until the connector seal is in contact, tighten the screw connection applying a torque as shown in Fig. 7; Pay regard to the screw head gasket
6. For more electric cabling see Fig. 9.
7. Protect electrical connections against moisture.

8. Avoid cable lengths over 6 m. Do not run signal lines parallel to power lines! If necessary, take measures against interference and EMC coupling.

**DANGER!**



Any non-observance of these instructions or the technical parameters may cause the Oil Level Controllers / System to fail.  
Most serious injuries and death possible.  
Only qualified electricians shall work on electrical systems.

**ATTENTION!!**



Any mix-up of connections may cause a short circuit.  
Minor, reversible injuries cannot be excluded.  
Any non-observance may cause Oil Level Controllers to fail.

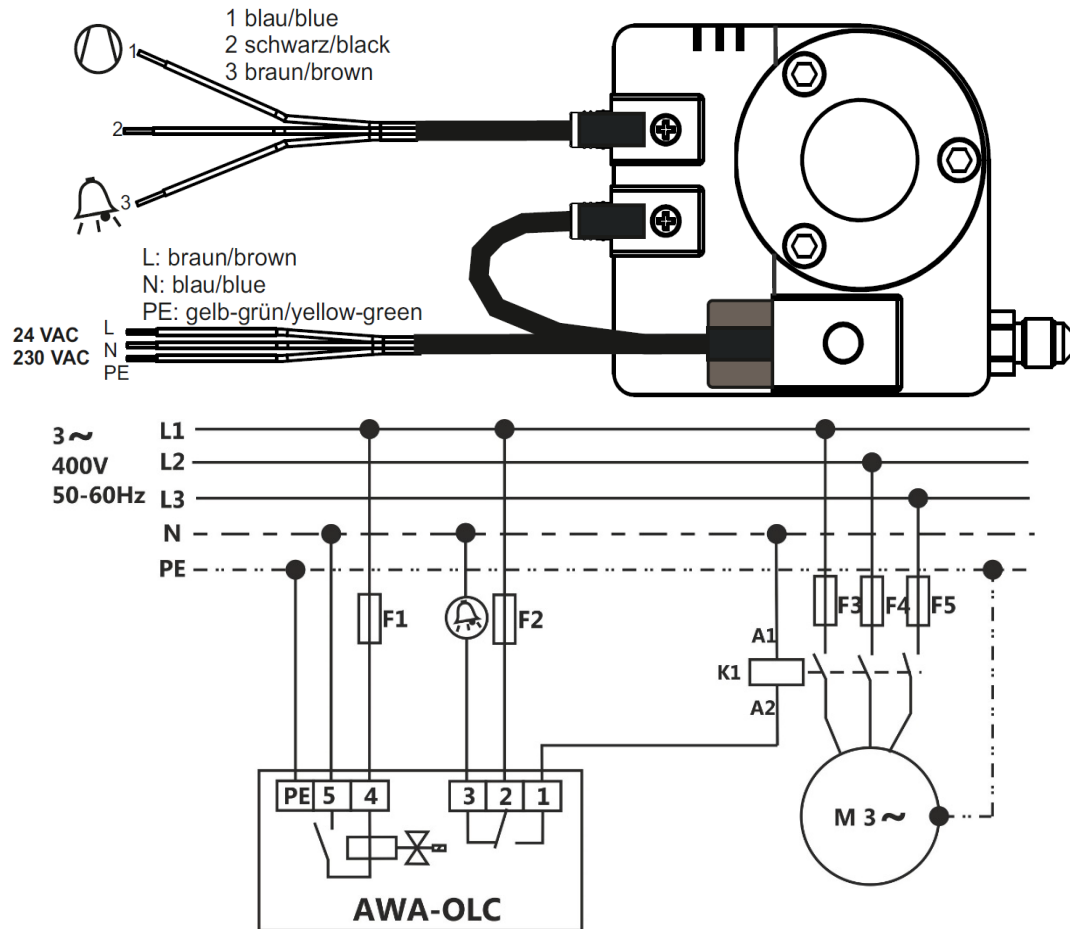

figure 6: Electrical connection

## Commissioning

### Principles

- The Oil Level Controller has already been tested for leakage and strength by the manufacturer.
- The Oil Level Controller and the System into which it is installed, may only be commissioned if they have been checked with due regard to the intended mode of operation, for proper condition as to assembly, installation, set-up conditions and safe functioning.
- After installation and prior to initial start-up, the System needs to be checked for leakage in accordance with EN 378-2:2012.

## Steps of commissioning

1. Check the System for leakage and resistance to pressure by suitable means (e.g. helium, dry nitrogen).

	<b>DANGER!</b>
	Risk of bursting of Oil Level Controller. Most serious injuries possible.
	The test pressure must not exceed the maximum permissible pressure (PS) per chamber.
	Strictly observe the safety regulations (e.g. EN 378).

2. It may be necessary to apply corrosion protection adapted to the conditions of use. Make sure that manufacturer's information remains legible at all times.

	<b>ATTENTION!</b>
	Loss of product conformity due to removal of lettering.
	Warranty becomes null and void.
	Lettering must remain legible.

3. Evacuating and filling of System with refrigerant and refrigerant oil resp.

	<b>DANGER!</b>
	Risk of bursting if operated beyond the technical parameters. Most serious injuries possible.
	Observe the technical parameters of the Oil Level Controller.
	Prevent the System from being overfilled with refrigerant oil.

	<b>WARNING!</b>
	Excessive torques may cause failures.
	Serious injuries and system failure during operation are possible.
	Observe the torques.

	<b>CAUTION!</b>
	Cracks of piping and the Oil Level Controller due to vibration loads are possible.
	Injuries and system failure during operation are possible.
	Avoid strong vibrations, take protective measures if necessary.

## Operation, Maintenance and Repair

### Principles

- The Oil Level Controller is maintenance-free.
- Pressure oscillations in the oil level measuring chamber must be limited to the maximum operating pressure for chamber 2 on the system side.
- As part of the regular system inspection it should be checked for damage and functioning and its proper condition restored.

	<b>WARNING!</b>
	Media contact possible, contact with hot/ cold surfaces. Burns, frostbites. Wear personal protective equipment during maintenance and inspection as prescribed by national regulations.

	<b>DANGER!</b>
	Risk of bursting of Oil Level Controller. Most serious injuries possible. The test pressure must not exceed the maximum allowable pressure (PS). Strictly observe the safety regulations (e.g. EN 378).

	<b>DANGER!</b>
	Electric shock due to insulation fault and breakage of live parts. Most serious injuries and death possible. Defective parts to be replaced after immediately disconnection.

### Repair

- If a proper functioning of the Oil Level Controller is no longer guaranteed, switch the system (or system section) off, drain the refrigerant from the system (or system section) in an eco-friendly manner and vent the system (or system section).
- Before any work is done on electrical lines and components, make sure they have been disconnected and check for a zero voltage condition.

	<b>DANGER!</b>
	Refrigerant oil may escape. Leaking refrigerant oil may cause most serious injuries. For repairs the System must have the right temperature, free from refrigerant oil and sufficiently ventilated.

- The basic unit of the oil regulation system, including the electrical control unit, cannot be repaired. A faulty device must be removed from the system and replaced with a new one.
- Only AWA original spare parts (seals, compressor adapter, solenoid coil, cable, inlet connection including strainer, level indicator) are to be used for the repair.

	<b>WARNING!!</b>
	Damage to Oil Level Controller due to defective spare parts or incorrect installation. Avoidable serious injuries and system failure possible. Use no other than original AWA spare parts for repairs.

- Install/commission according these instructions. It is imperative to carry out another leakage and strength test. No warranty is accepted by AWA for tightness in case of repair.

## Dismantling and Disposal

### Principles

- To dismantle the Oil Level Controller, shut off the System / segment, remove the refrigerant oil in an environmentally friendly manner and sufficiently vent the area.

	<b>DANGER!</b>
	Possible escape of refrigerant oil. Escaping refrigerant oil may cause most serious injuries. For repairs the System must have the right temperature, free from refrigerant oil and sufficiently ventilated.

	<b>DANGER!</b>
	Electrical shock may result from contact with live parts. Electrical shock may cause immediate most serious injuries or death. Disconnect the lines prior to dismantling and check for zero voltage condition.

	<b>WARNING!</b>
	Media contact possible, contact with hot/ cold surfaces. Burns, frostbites Wear personal protective equipment during maintenance and inspection as prescribed by national regulations.

- The Oil Level Controller and its component parts resp. can be recycled:

Oil control body:	aluminium scrap/electric scrap
Oil connection:	stainless steel/brass
Sight glass:	steel/glass
Solenoid valve:	steel/brass
Magnetic coil:	electric scrap



### **Armaturenwerk Altenburg GmbH**

Am Weißen Berg 30  
D-04600 Altenburg - Germany

Phone +49 (0) 3447-893-0  
Fax +49 (0) 3447-811-10

Internet: <http://www.awa-armaturenwerk.de>  
email: [info@awa-armaturenwerk.de](mailto:info@awa-armaturenwerk.de)

Subject to change. As of 03.2024  
Document 90000722 Revision 02